



CURTIS

Motor Controllers



# AC Induction Motor Controllers

## SE SERIES

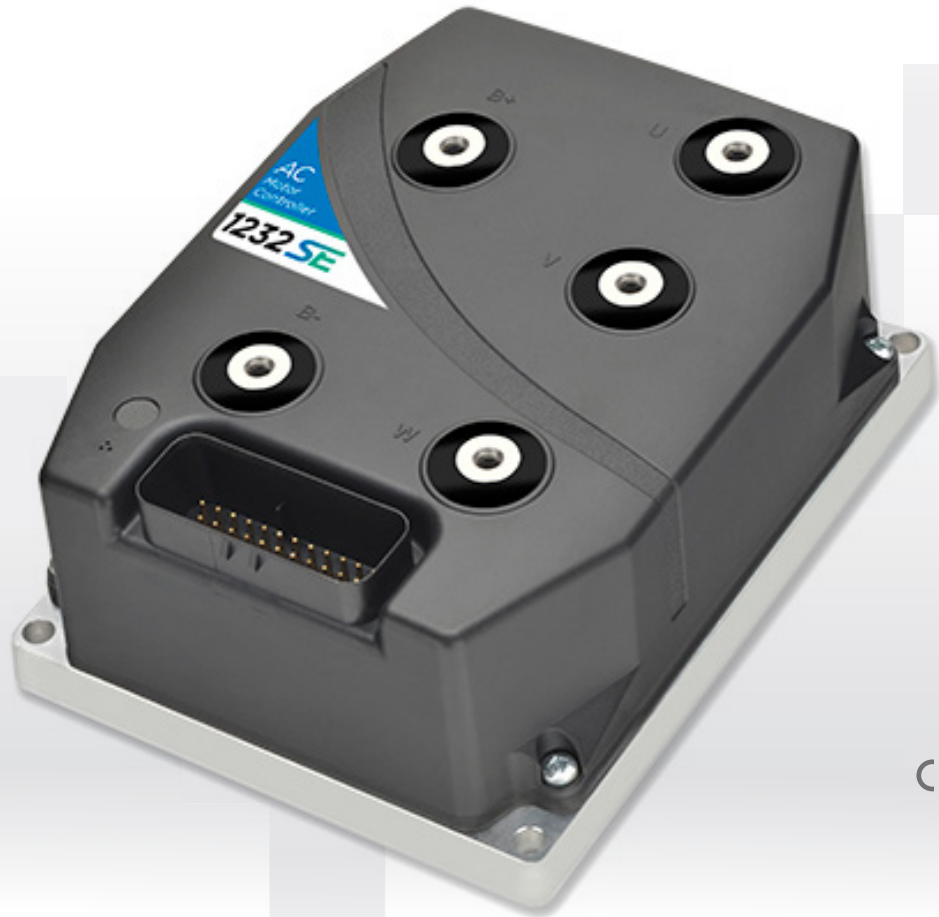

CE 





## Models 1232SE / 1234SE / 1236SE

A range of controllers (inverters) for the speed and torque control of 3-phase AC motors rated from 1kW to 25 kW. Intended for use as electric traction or hydraulic pump motor controllers for mobile, on-vehicle applications that use a 24-80Vdc nominal battery supply.

### The 'SE' Advantage

The Curtis 'SE' AC controllers utilize the latest technology to increase the peak current ratings for each size of controller. For a given rating, the SE models are smaller and lower cost than previous Curtis AC controllers, benefits that are highly advantageous for all types of applications.

### Only Curtis AC can offer:

**Curtis VCL™—Vehicle Control Language** is an easy to use programming language that allows vehicle developers to write powerful logic functions and create a 'virtual system controller.' Curtis offers customers VCL development tools and training. Curtis also provides a VCL service where Curtis engineers will work with the OEM to create any custom VCL code required.

**Indirect Field Orientation (IFO) Vector Control** algorithm generates the maximum possible torque and efficiency across the entire speed range. Advanced Curtis IFO vector control provides superb drive 'feel', improved speed regulation and increased gradeability.

**Curtis Auto-Tune** function enables quick and easy characterization of the AC motor without having to remove it from the vehicle. Curtis AC controllers are fully compatible with any brand of AC motor.

**Dual-Drive Functionality** is standard, allowing correct control of applications featuring twin traction motors. This function ensures smooth and safe operation, minimal tire wear and correct load sharing between the traction motors at all times.

**Configurable CANbus** connection allows communication with other CANbus enabled devices. They are CANopen compatible and provide 24 VCL-configurable CAN 'mailboxes'—10 more than earlier Curtis AC controllers.

**Integrated System Controller**—More than just a motor controller, they are also powerful system controllers. They feature a comprehensive allocation of multi-function I/O pins for use as analog inputs, digital inputs, contactor coil drivers and proportional valve drivers. In addition to this local I/O, these controllers can use VCL to map and configure the remote I/O available on other CANbus devices, send messages to CAN displays and thus control and monitor the entire system.



See a 360° view of Model 1232SE:  
[curtisinstruments.com/360view](http://curtisinstruments.com/360view)



See a 360° view of Model 1234SE:  
[curtisinstruments.com/360view](http://curtisinstruments.com/360view)



See a 360° view of Model 1236SE:  
[curtisinstruments.com/360view](http://curtisinstruments.com/360view)





## Models 1232SE / 1234SE / 1236SE



### FEATURES

#### Increased Performance, Improved Functionality

- ▶ Higher peak current rating allows use of a physically smaller controller for a given load, for easier installation in any vehicle.
- ▶ CE marked as a programmable safety device under EN ISO 13849-1.
- ▶ Models available for 250A–1000A output at 24–80V system voltages. These are true 2 minute RMS ratings, not short duration ‘boost’ ratings.
- ▶ Enhanced 64MHz micro and additional FLASH memory doubles the available VCL code space and provides more than twice the VCL execution speed.
- ▶ VCL-configurable CAN ‘mailboxes’ provide highly flexible CAN master capabilities.
- ▶ Advanced Pulse Width Modulation techniques produce low motor harmonics, low-torque ripple and minimized heating losses, resulting in high efficiency.

#### Unmatched Flexibility

- ▶ Programmable for either traction or pump applications.
- ▶ Field upgradeable software.
- ▶ Integrated battery state-of-charge algorithm and hour meters.
- ▶ Fully-featured generic software and VCL for typical Warehouse Truck applications is included on 24V 1232SE and 1234SE models.
- ▶ Comprehensive programming options and VCL allow other applications to be easily supported.
- ▶ Curtis hand-held or PC Windows programming tools provide easy programming and powerful system diagnostic tools.
- ▶ Integrated status LED provides instant diagnostic indication.



## Models 1232SE / 1234SE / 1236SE

### FEATURES continued

#### Robust Safety and Reliability

- ▶ Dual Microprocessor architecture cross-checks critical circuits, logic, and software functions to ensure the highest possible functional safety performance level is achieved.
- ▶ Insulated metal substrate power-base provides superior heat transfer for increased reliability.
- ▶ Fail-Safe power component design.
- ▶ Reverse polarity protection on battery connections.
- ▶ Short circuit protection on all output drivers.
- ▶ Thermal cutback, warning, and automatic shutdown provide protection to motor and controller.
- ▶ Rugged sealed housing and connectors meet IP65 environmental sealing standards for use in harsh environments.

#### Meets or complies with relevant US and International Regulations

- ▶ EMC: Designed to the requirements of EN12895.
- ▶ Safety: Designed to the requirements of:
  - EN1175-1:1998+A1:2010
  - EN (ISO) 13849-1
- ▶ IP65 Rated per IEC 60529.
- ▶ UL recognized per UL583.
- ▶ Regulatory compliance of the complete vehicle system with the controller installed is the responsibility of the vehicle OEM.

### FUNCTIONAL SAFETY DATA

Model	Safety Function	PL	Designated Architecture	MTTFd	DC
1232SE / 1234SE	Uncommanded Powered Movement	d	Category 2	≥40 yrs	≥90%
1232SE / 1234SE	Motor Braking Torque	c	Category 2	≥16 yrs	≥90%
1236SE	Uncommanded Powered Movement	d	Category 2	≥36 yrs	≥90%
1236SE	Motor Braking Torque	c	Category 2	≥16 yrs	≥90%

### MODEL CHART

Model	Nominal Battery Voltage (V)	2 Min RMS Current Rating (A)	S2-60 Min RMS Current Rating (A)
1232SE-24XX	24	375	185
1232SE-53XX	36-48	350	175
1232SE-63XX	48-80	250	145
1234SE-45XX	24-36	500	235
1234SE-54XX	36-48	450	215
1234SE-63XX	48-80	350	150
1236SE-46XX	24-36	650	285
1236SE-56XX	36-48	600	260
1236SE-65XX	48-80	450	185



Models 1232SE / 1234SE / 1236SE

## SYSTEM ACCESSORIES



**The Curtis Model 1222** is an AC induction motor controller for 'steer by wire' electric power steering systems and is the ideal partner for the 'SE' Controllers on vehicles such as reach trucks, order pickers, stackers and other similar industrial vehicles.



**The Curtis Model 1352** CANbus I/O expansion module features 9 I/O pins, including 6 proportional valve drivers. This module can be used to further expand the I/O capability of Curtis AC motor controllers using VCL.



**The Curtis Model 1313** Handheld Programmer is ideal for setting parameters and performing diagnostic functions.

Contact Curtis to obtain the VCL Vehicle Control Language compiler and development tools.

## CONNECTOR WIRING

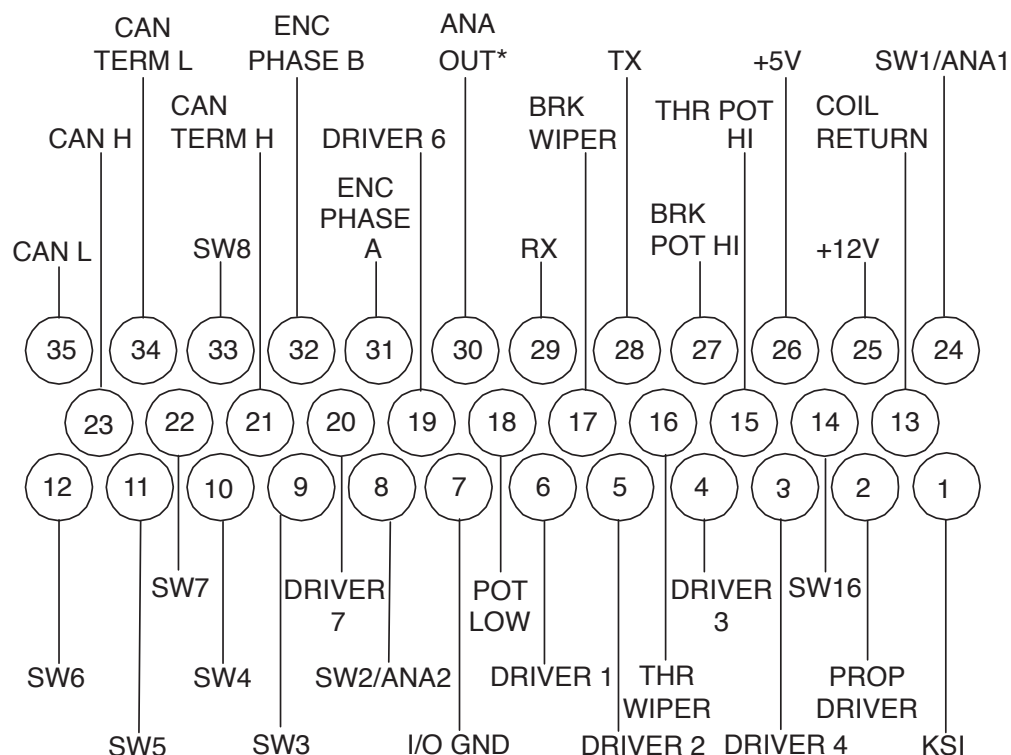

\*This pin is not connected on 1232SE



Models 1232SE / 1234SE / 1236SE

## TYPICAL WIRING

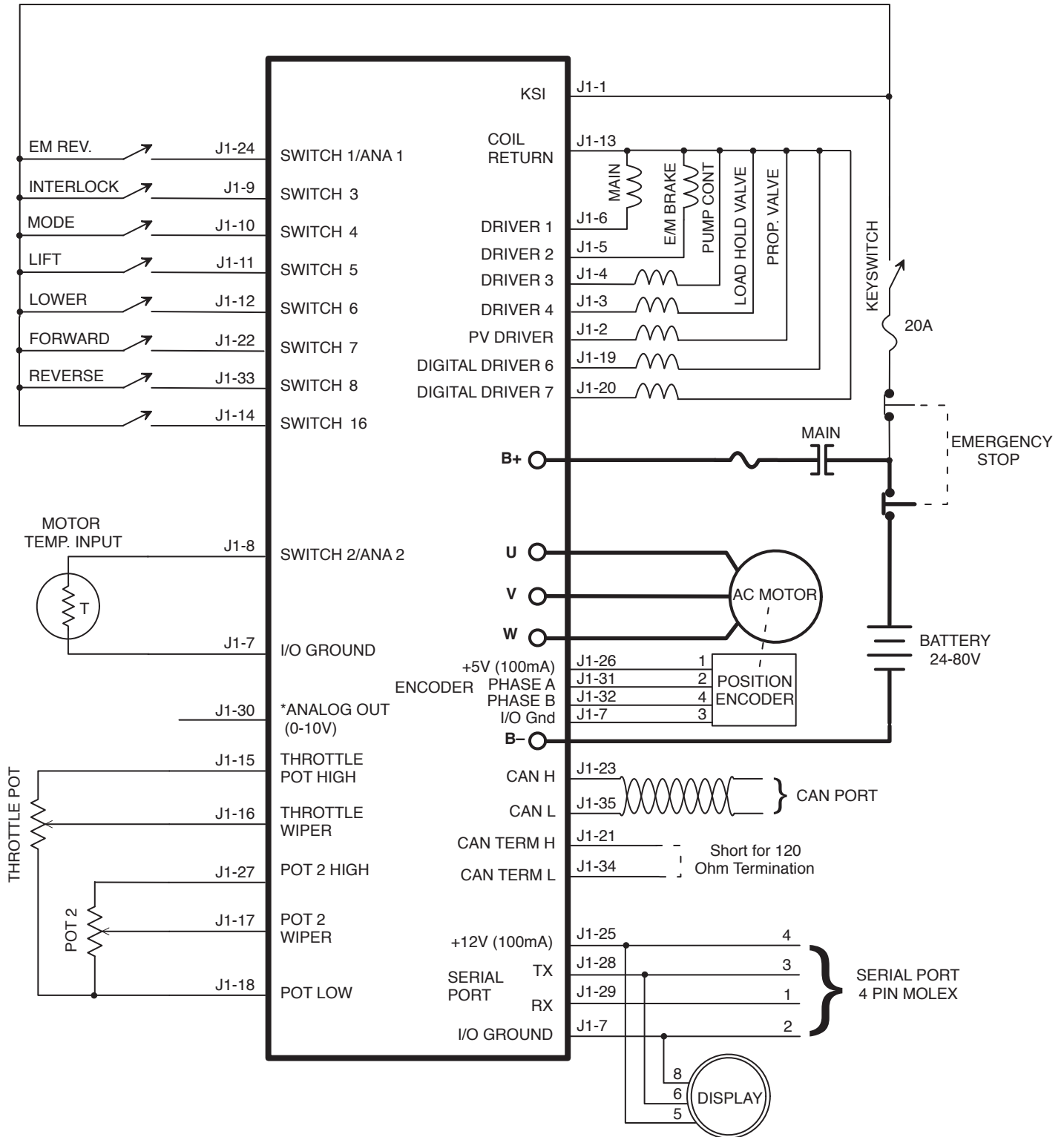

\*1232SE controller does not include the ANALOG OUT.



Models 1232SE / 1234SE / 1236SE

## DIMENSIONS mm (typical)

### 1232SE

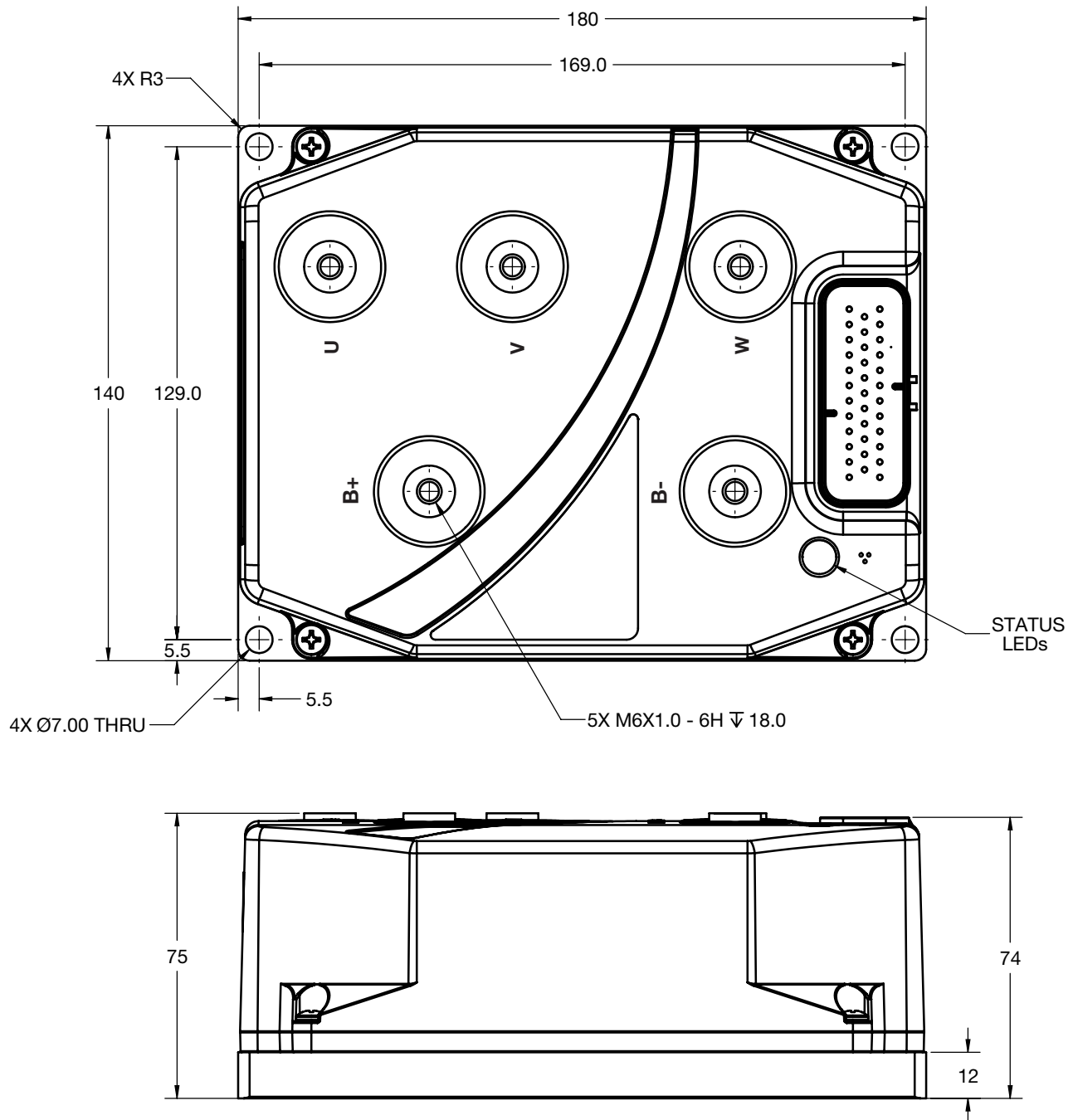



Models 1232SE / 1234SE / 1236SE

## DIMENSIONS mm (typical)

### 1234SE

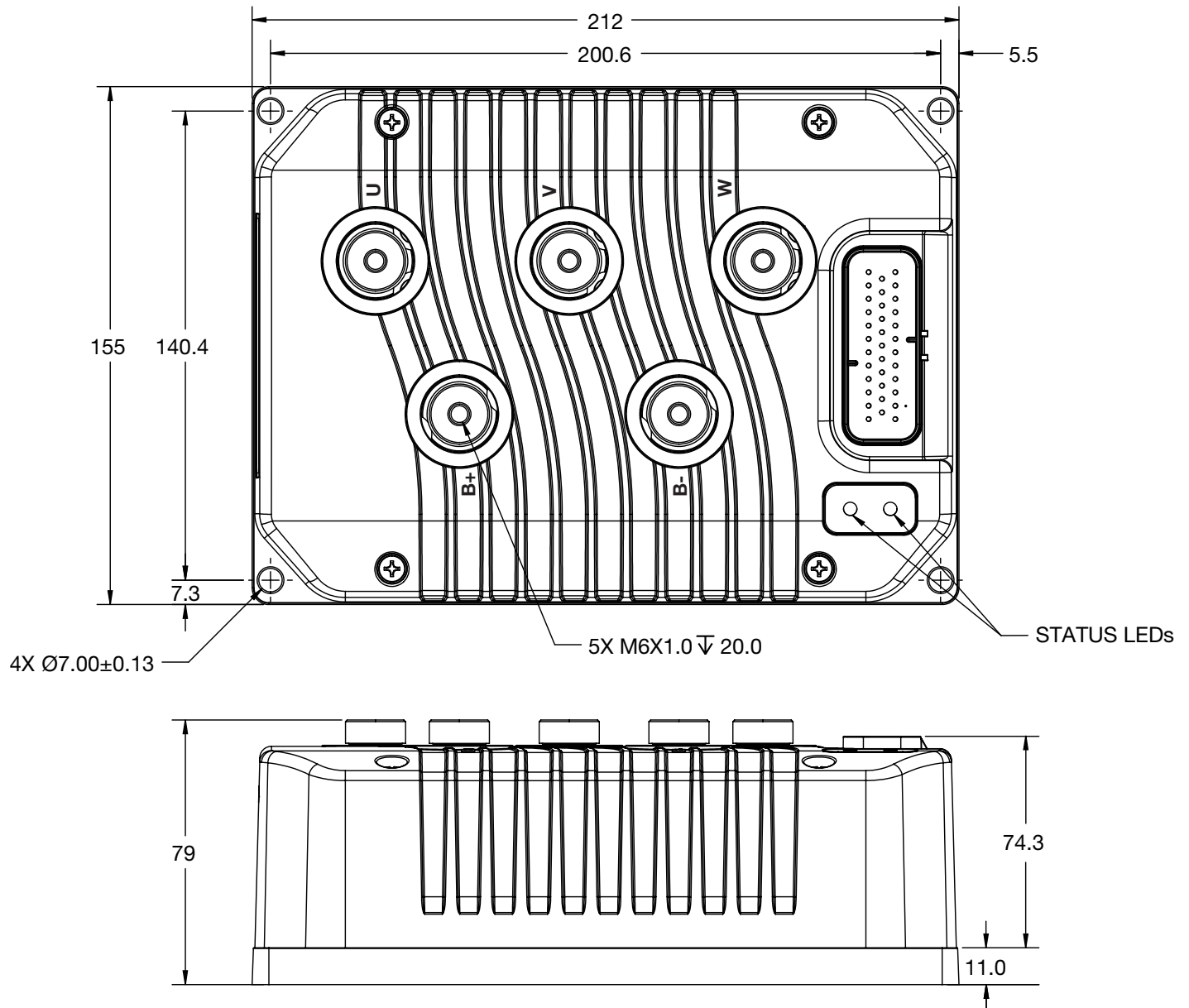





Models 1232SE / 1234SE / 1236SE

## DIMENSIONS mm (typical)

### 1236SE

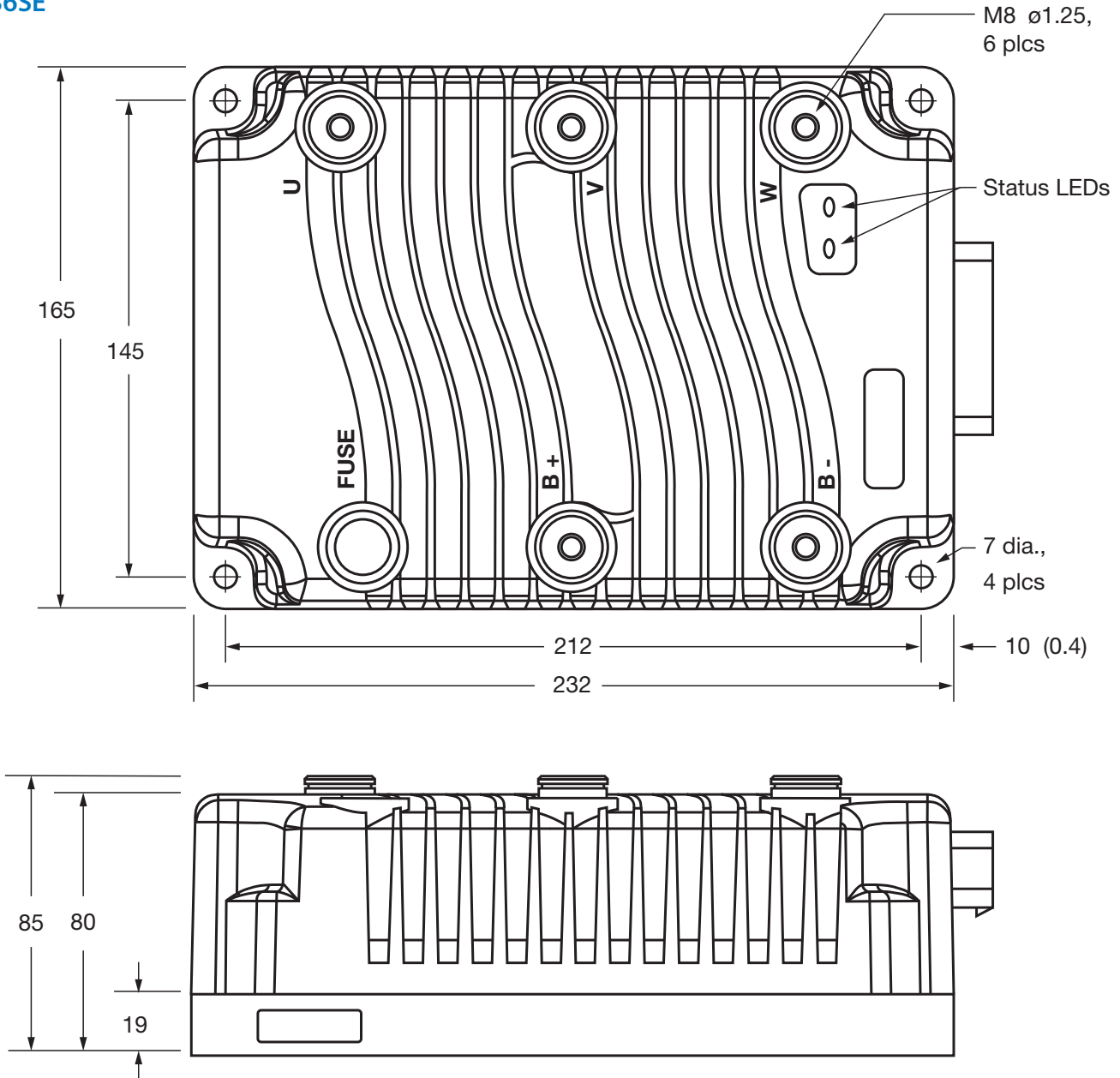

**WARRANTY** Two year limited warranty from time of delivery.

The Curtis Difference   
**You feel it when you drive it**



is a trademark of Curtis Instruments, Inc.

Specifications subject to change without notice

©2018 Curtis Instruments, Inc.

50288 REV G 3/18