

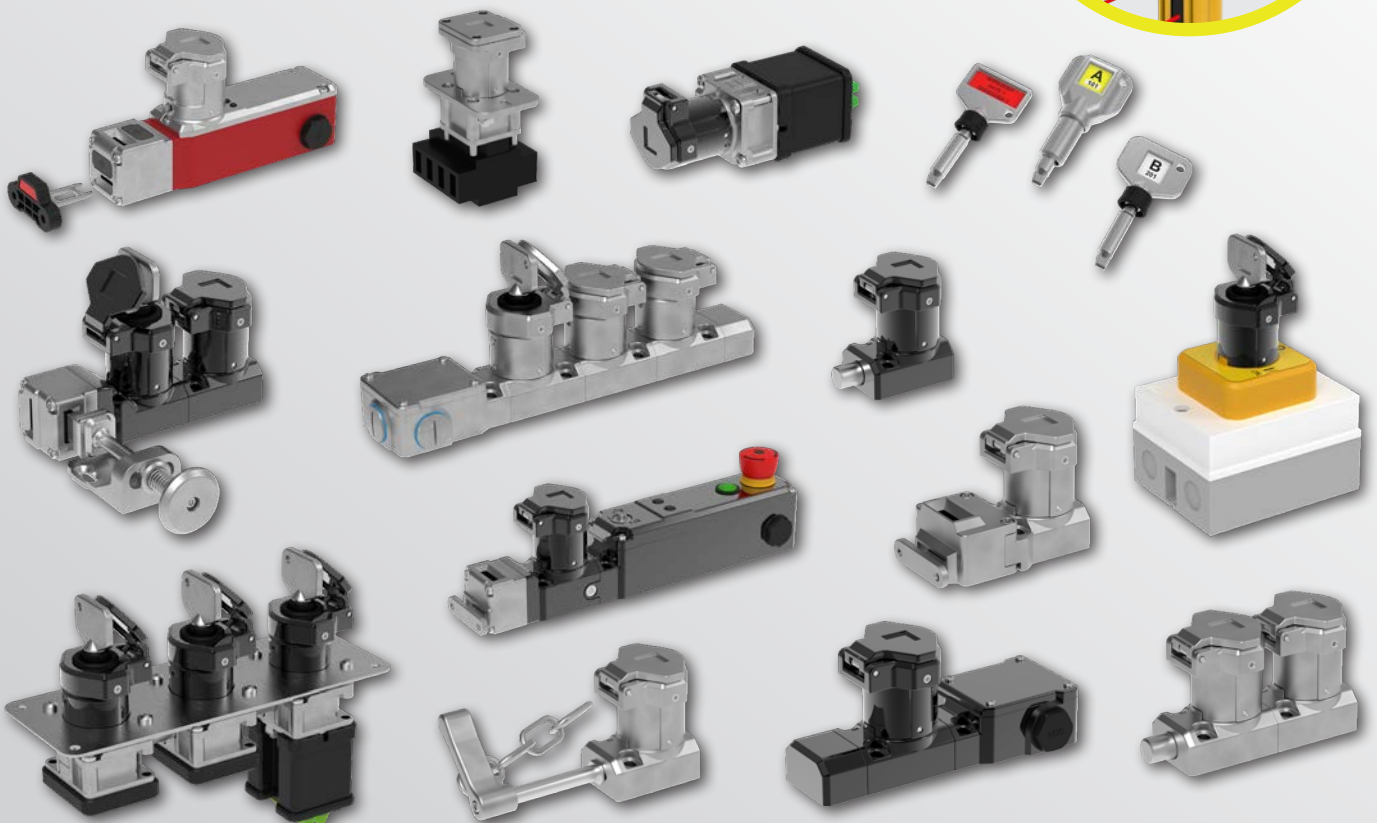

IDEM Safety Switches

Trapped Key Interlocking Brochure

NEW LIGHT CURTAIN BLOCKING
DEVICE INSIDE PAGE 18

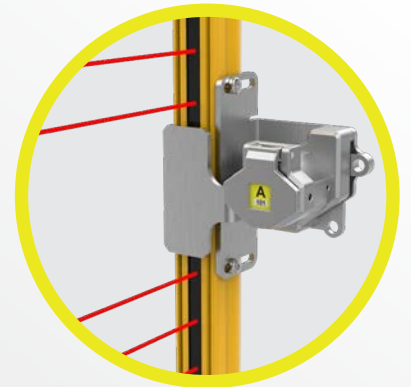

Leading Manufacturer of Machine Safety Switches & Solutions

idemsafety.com

idemsafetyusa.com



What We Do

IDEM designs and manufactures machine safety products, that make industry safer.



Proud Winners of

The Queen's Award for Enterprise: International Trade 2022

The King's Award for Enterprise: Innovation 2023

The King's Award for Enterprise: Innovation 2024

Our History

1985

The founder of IDEM, Medi Mohtasham begins his employment at EJA Engineering where he designed Trojan, Atlas, Rotacam and LRS1 under the Guardmaster brand. Rockwell Automation acquires EJA in 1996.

2003

Medi leaves his position as Technical Director of Rockwell to create IDEM Safety Switches, with the vision to develop the 'Next Generation' of Safety Switches, designed and manufactured in the UK.

2005

IDEM manufactures the GuardianLine range of safety rope switches, specialising in products for the Food Industry, Explosion Proof applications and Factory Automation.

Present

Today IDEM operates globally, providing reliable, cost-effective safety interlock solutions that save lives. IDEM continues to invest in new ways to protect your personnel and improve your productivity.

Why Choose IDEM?



Global leadership in the design and manufacture of machine safety products since 1985.



IDEM's global headquarters is based in the UK with offices in the USA and Europe.



Privately owned business with in house sales, R&D and technical support teams.



Renowned for world-class product quality and reliability on a global scale.



State-of-the-art manufacturing and test facilities. This includes Ingress Protection (IP) and Shock testing.



Exceptional delivery time for both small and large orders. We put the customers' needs first.

TRAPPED KEY INTERLOCKING SYSTEMS

WHAT ARE SKORPION TRAPPED KEY INTERLOCKS

IDEM's Trapped-key interlocks utilise locks and coded keys for sequential control of equipment and machinery to ensure safe operation. Trapped-key interlocks are widely used to ensure safe access to potentially live or dangerous plant or equipment in an industrial setting.

- Mirror Polished Die-Cast Metal
- 316 Stainless Steel (IP69K)
- Designed and Manufactured in the UK
- Comprehensive Range
- Robust with high Mechanical Integrity
- Thousands of Codes Available

ISOLATION

The first stage of any trapped key system is to isolate the power or control circuit, effectively stopping any hazardous processes.

KEY EXCHANGE

The second stage is the exchange process. The isolator key can either open a single access lock directly or be inserted into a key exchange unit to release multiple access keys, enabling access to more than one point safely.

ACCESS CONTROL

The third stage involves access locks, which prevent entry into hazardous areas. Access is only granted when the correct coded key is inserted.

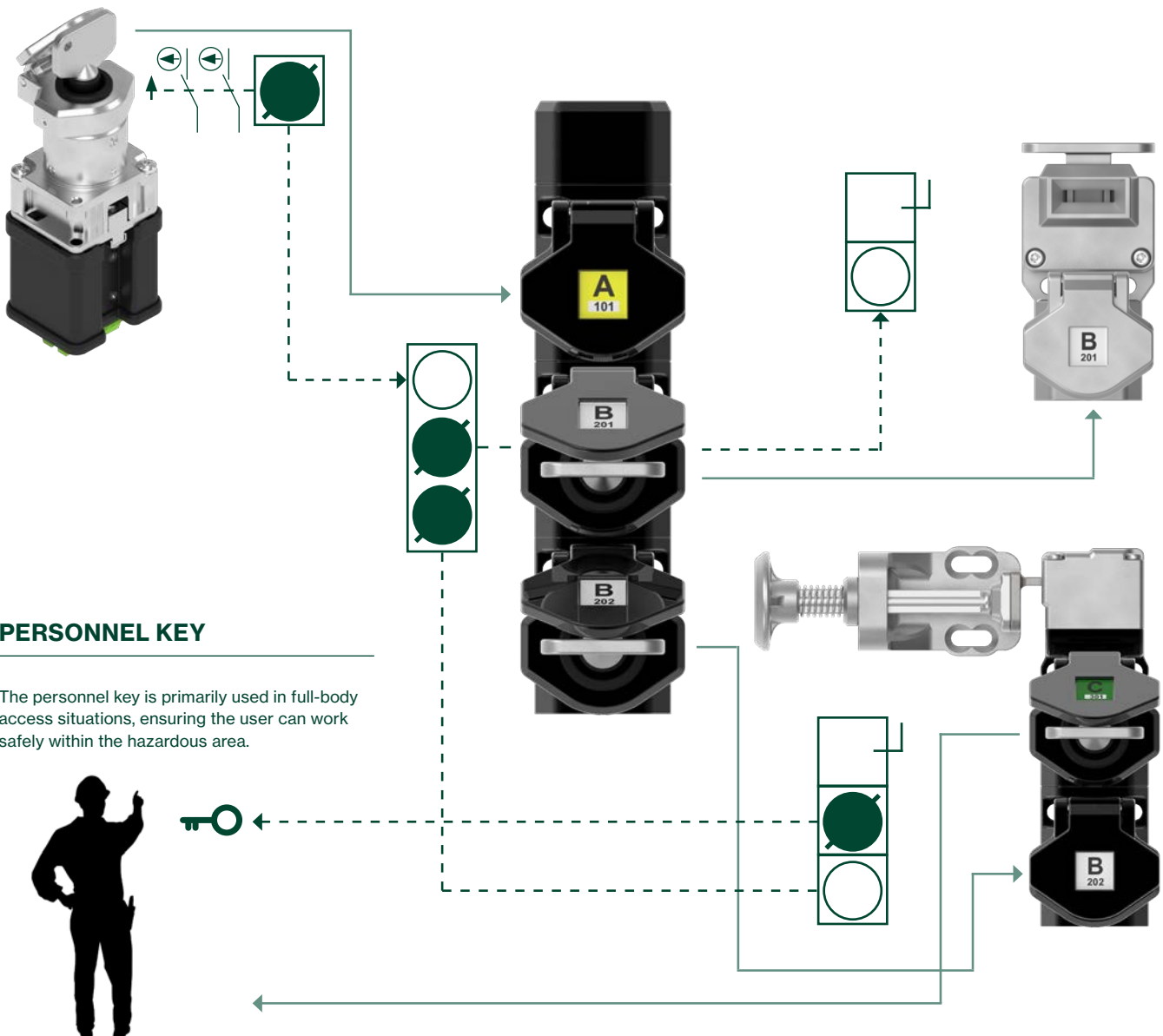

PERSONNEL KEY

The personnel key is primarily used in full-body access situations, ensuring the user can work safely within the hazardous area.

ADDITIONAL FEATURES

IDEM Trapped Key Interlocks offer a wide range of additional features to enhance functionality and flexibility. These include various dustcover options, which can be customized with specific labels and fitted with holes to accommodate padlocks.



DUST COVERS

Trapped key systems operate by using uniquely coded keys in a defined sequence to safely isolate and access hazardous machinery. Dust covers help visually identify key locations, ensuring proper usage and improving safety.

DEFAULT DUST COVER



Standard dust covers are included by default with every trapped key order.

CK DUST COVER



Custom label dust covers offer additional space for text and are used when specific labelling is required.

LT DUST COVER



Lockout dust covers feature four holes compatible with padlocks or hasps. The dustcover with the "key out" will be chosen by default (see diagram 1).

HOW TO ORDER SPECIAL DUST COVERS

The part number below serves as a standard example for ordering an IDEM trapped key. If no special dust cover is required, use the standard part number as shown.

For variations, append the following codes to the end of your part number:

CK – Add this suffix to the end of the part number for a lockout dust cover

LT – Add this suffix to the end of the part number for a custom label dust cover

SS - HT - D - L - 11 - []

Standard Dust Cover

↓
CK

Custom Label Dust Cover

↓
LT

Lockout Dust Cover

LT DUSTCOVER DIAGRAM 1

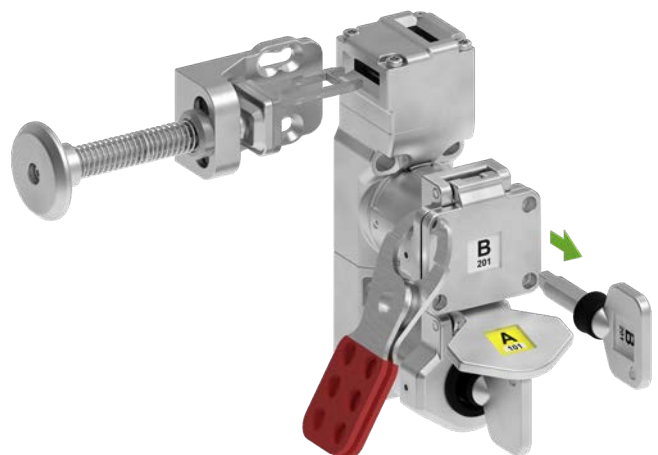

CODED KEY SELECTION

STANDARD KEY (SK)



SK keys are used as standard, with all Sales Numbers beginning with 'SK-', followed by a letter and three digits (e.g., SK-C306)

EJECTOR KEY (EK)



EK ejector keys are used when a secondary function requires the operator to carry the key into a hazardous area, serving as a physical reminder to take the key before entry. All Sales Numbers begin with 'EK-', followed by a letter and three digits (e.g., EK-C306)

Different key fob colours are available based on the selected code, providing a visual aid for the end-user. For example, the Primary Key can be assigned a distinct colour to easily differentiate it from the Released Keys within the system.

- Thousands of additional key codes available on request.

Yellow		White		Green		Blue	
A101	A111	B201	B211	C301	C311	D401	D411
A102	A112	B202	B212	C302	C312	D402	D412
A103	A113	B203	B213	C303	C313	D403	D413
A104	A114	B204	B214	C304	C314	D404	D414
A105	A115	B205	B215	C305	C315	D405	D415
A106	A116	B206	B216	C306	C316	D406	D416
A107	A117	B207	B217	C307	C317	D407	D417
A108	A118	B208	B218	C308	C318	D408	D418
A109	A119	B209	B219	C309	C319	D409	D419
A110	A120	B210	B220	C310	C320	D410	D420

Unique key coding is available upon request. Please contact IDEM Safety for more details on this option.

CUSTOM KEY (CK)

CHOOSE YOUR COLOUR

5 colours are available to choose from.



← LABEL

Fully customizable label – any character configuration can be used, provided it fits within the 33 × 12 mm space.

HOW TO ORDER

For custom labels, replace the SK- and EK- prefixes with CK- using the key codes provided in the table above (e.g., CK-A101). By default, the following colours are applied based on the selected code: A = Yellow, B = White, C = Green, D = Blue, and E = Red. To specify a different colour, please indicate your preference when placing the order.

ISOLATION

METHODS OF ISOLATION FOR HAZARDOUS AREAS

Isolation refers to the process of safely removing power or interrupting control signals to hazardous areas, preventing unintended operation and ensuring personnel safety. Several effective methods for achieving isolation are outlined below including steps that must be considered when isolating hazardous energy.

- ▶ Locate and document every energy source connected to the machinery or equipment to ensure nothing is overlooked.
- ▶ Create clear, step-by-step instructions for safely isolating, securing, and marking each energy source during maintenance or servicing.
- ▶ Educate and train staff to confidently follow isolation and lockout procedures, emphasizing safe practices.
- ▶ Equip employees with the appropriate locking devices, tags, and supporting tools necessary to carry out energy control measures.
- ▶ Periodically audit and revise procedures to maintain their effectiveness and adapt to any changes in the work environment or equipment.

PANEL MOUNTED



Panel-mounted isolation switches are designed for direct installation onto control cabinet doors, providing convenient access for isolating power or control circuits. This is the most widely used method, as it enables direct integration into the associated safety circuit or power supply, enhancing safety and ease of operation.

- ▶ **Reduced Wiring Complexity:** Minimizes wiring length and simplifies connections.
- ▶ **Space Efficiency:** Integrates seamlessly into the existing control panel, saving valuable space.
- ▶ **Enhanced Reliability:** Reduces potential points of failure by limiting external wiring.
- ▶ **Clear Visual Indication:** Enables quick verification of isolation status directly at the control panel.

BOX MOUNTED



Box-mounted isolation switches are typically used when space within the control panel is limited or when isolation is required closer to the application. Housed in robust enclosures, they offer durable protection and simplify connection to power or control circuits.

- ▶ **Closer to the Hazard:** Enables isolation to be positioned near the machine or hazardous area, reducing response time and increasing operator safety.
- ▶ **Saves Panel Space:** Frees up valuable space inside the main control panel by relocating isolation externally.
- ▶ **Easier Access for Operators:** Provides convenient access for isolation without needing to open control cabinets.
- ▶ **Versatile Placement:** Can be mounted in various locations, even in harsh environments, thanks to robust enclosures.
- ▶ **Minimizes Downtime:** Speeds up maintenance and troubleshooting by providing a dedicated, easily accessible isolation point.

ISOLATION

HEAVY-DUTY ENCLOSURES FOR EXTERNAL MOUNTING



Externally mounted control switches work on the same principle as the box mounted versions however, they are enclosed in a robust metal body. These versions are monitored control switches only and are not suitable for switching large power supplies.

- ▶ **Closer to the Hazard:** Enables isolation to be positioned near the machine or hazardous area, reducing response time and increasing operator safety.
- ▶ **Saves Panel Space:** Frees up valuable space inside the main control panel by relocating isolation externally.
- ▶ **Easier Access for Operators:** Provides convenient access for isolation without needing to open control cabinets.
- ▶ **Versatile Placement:** Can be mounted in various locations, even in harsh environments, thanks to robust enclosures.
- ▶ **Enhanced IP Rating:** External enclosures offer superior ingress protection, with stainless steel versions rated up to IP69K

MECHANICAL ISOLATION



Mechanical isolation devices, such as bolt interlocks, provide a robust method of isolating electrical switchgear to prevent the unintended return of hazardous electrical energy.

BS and BD interlocks are specifically designed to prevent access to control panels until the switchgear has been safely isolated. When the key or keys are removed, the bolt is locked in the extended position, physically preventing the re-energization of the switchgear until the correct key is returned. This ensures that strict power isolation procedures are followed before access is granted.

- ▶ **Improves Personnel Safety:** Physically prevents access to live electrical components by ensuring isolation before panels can be opened or
- ▶ **Enforces Safe Operating Procedures:** Guarantees that operations such as switching, grounding, or disconnection occur in a controlled and safe sequence.
- ▶ **No Dependence on Power Supply:** Operates purely mechanically without the need for electrical wiring or control circuits, providing fail-safe protection.
- ▶ **Prevents Costly Damage:** Reduces the risk of arc flashes, equipment damage, and downtime by ensuring switches and breakers are correctly operated and isolated.

ISOLATION OF SMALL VALVES

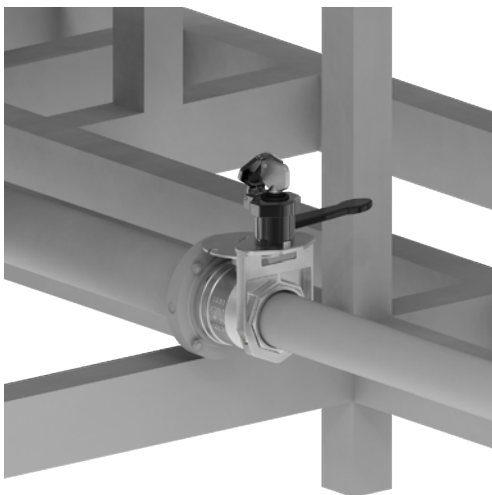

Valves play a crucial role in ensuring safety across various process industries. Incorrect opening and closing of valves can lead to disastrous consequences, causing severe or even fatal injuries to operating personnel, product loss, equipment damage and environmental pollution.

To ensure safe operation across industries such as water and food production, chemical manufacturing, and oil refining, it is essential to guarantee the safe operation of valves.

- ▶ **Enhances Safety:** Ensures valves are operated in a pre-determined, safe sequence to prevent accidental release of hazardous substances.
- ▶ **Mechanical Reliability:** Provides a robust, tamper-resistant method for controlling valve operations without relying on electrical systems.
- ▶ **Process Integrity:** Reduces human error by enforcing a strict operational procedure, helping maintain consistent process control and compliance.

ISOLATION

ELECTRICAL ISOLATION

PANEL MOUNTED



ISP - ISOLATOR

- 690V contact block available 25/40/63/100A
- Die-Cast or 316 Stainless Steel

BOX MOUNTED



ISB1 - ISOLATOR

- 690V Contact Block available in 25A or 40A
- Die-Cast or 316 Stainless Steel Barrel

EXTERNAL MOUNTED

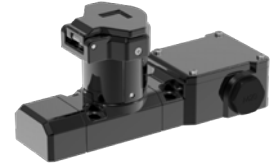

ISB-CB - CONTROL SWITCH

- Monitored Control Switch
- 2nc 2no, 3nc 1no or 4nc Contacts
- 240V 3A Max
- Die-Cast (IP67)
- 316 Stainless Steel (IP69K)



CS / CS-SKR - CONTROL SWITCH

- Monitored Control Switch
- Solenoid Controlled Versions (SKR)
- Die-Cast or 316 Stainless Steel
- 4nc 2no Contacts
- 240V 3A Max



ISB2 - ISOLATOR

- 690V Contact Block rated at 63A
- Die-Cast or 316 Stainless Steel Barrel

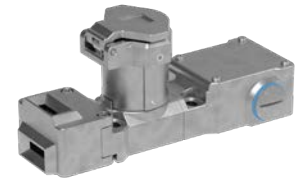

TS-CB - CONTROL SWITCH

- Key trapped, actuator unlocked
- 2nc 2no, 3nc 1no or 4nc Contacts
- 240V 3A Max
- Available with 1/2" NPT or M20 conduits



ISP - SKR - ISOLATOR WITH SOLENOID

- 690V contact block available in 25/40/63A 24V ac/dc solenoid voltage
- IP65 model available: ISP-SKR-WR
- Guard Status LED
- Die-Cast or 316 Stainless Steel



ISB3 - SKR - ISOLATOR WITH SOLENOID

- 690V contact block available in 25/40/63A, 24V ac/dc
- IP65 model available: ISB3-SKR-WR
- Guard Status LED
- Die-Cast or 316 Stainless Steel

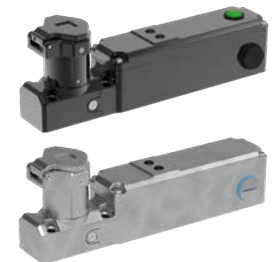

ISB4 - SKR - CONTROL SWITCH WITH SOLENOID

- 2nc 2no, 3nc 1no or 4nc Contacts
- 240V 3A Max 24V ac/dc solenoid voltage
- Guard Status LED
- Available with integral request button

ISOLATION

MECHANICAL ISOLATION

SINGLE KEY



BS - BOLT LOCK

- Key trapped when bolt retracted
- Die-Cast or 316 Stainless Steel

DUAL KEY

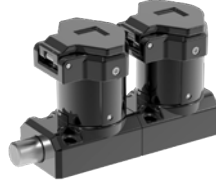

BD - BOLT LOCK

- BD-20 (Keys trapped when bolt retracted)
- BD-11 (1 Key IN / 1 key OUT to extract bolt)
- Die-Cast or 316 Stainless Steel

SINGLE + DUAL KEY



BS-CB / BD-CB - BOLT LOCK MONITORED

- BS-CB (Key trapped when bolt retracted)
- BD-20-CB (Keys trapped when bolt retracted)
- BD-11-CB (1 Key IN / 1 key OUT to extract bolt)
- 2nc 2no, 3nc 1no or 4nc (240V 3A Max)
- Available with 1/2" NPT or M20 conduits
- Die-Cast or 316 Stainless Steel

VALVE ISOLATION

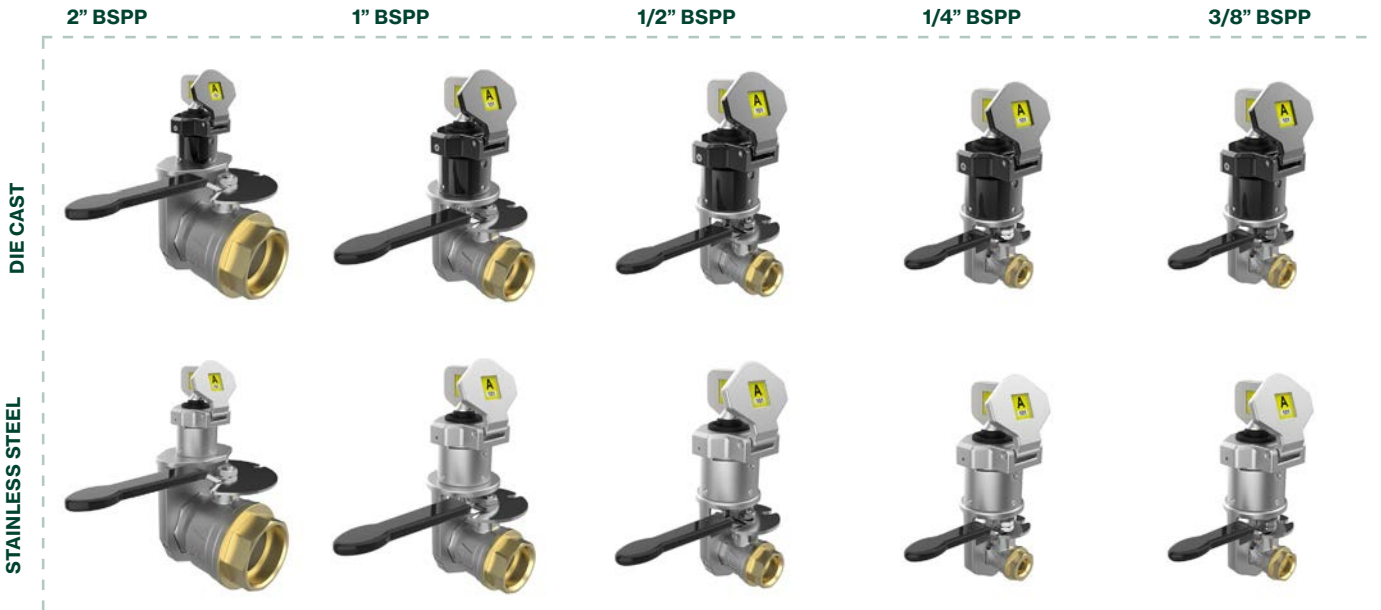

FOP: Indicates that the valve is fully open, and the interlock key can only be inserted or removed when the valve is in this exact position.

FCL: Indicates that the valve is in the fully closed position, and the interlock is engaged, meaning the valve is mechanically locked in that closed position.

Part Number	A (mm)	B (mm)	C (mm)	Valve Size BSP
MV-FCL 1/4	96	125	39	0.25 Inch
MV-FOP 1/4	96	125	39	0.25 Inch
MV-FCL 3/8	96	125	39	0.375 Inch
MV-FOP 3/8	96	125	39	0.375 Inch
MV-FCL 1/2	118	129	50	0.5 Inch
MV-FOP 1/2	118	129	50	0.5 Inch
MV-FCL 1	146	137	67	1 Inch
MV-FOP 1	146	137	67	1 Inch
MV-FCL 2	202	161	106	2 Inch
MV-FOP 2	202	161	106	2 Inch

KEY EXCHANGE

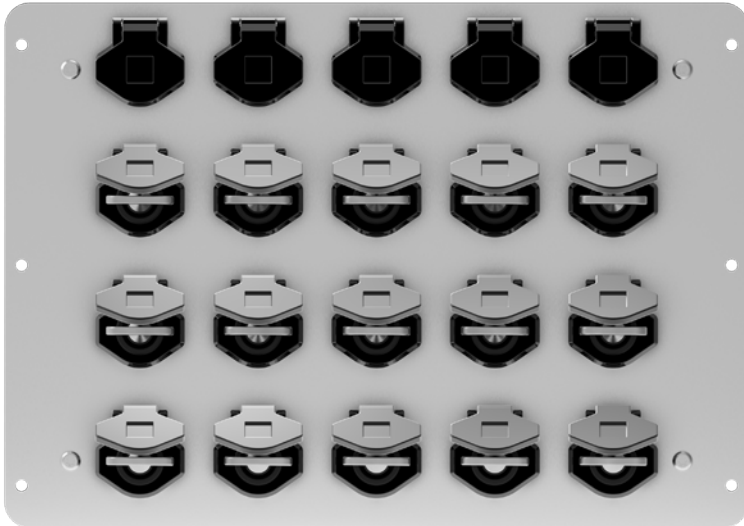

MULTI KEY EXCHANGE SYSTEM

The Multi-Key Exchange System is available for either panel or box mounting. It features robust barrels manufactured from die-cast metal or 316 stainless steel, making it suitable for use in harsh and demanding environments. Each barrel is fitted with a dust cap to protect against ingress and is equipped with a coloured key code label for easy identification.

The system operates by inserting between one and five keys (depending on the configuration), which then releases up to 15 secondary keys used to unlock access points.

The inserted keys can originate from isolation switches or, in certain applications, serve as authority keys – ensuring that all designated key holders must be present before access keys are released.

- ▶ **Supports Complex Safety Sequences:** Allows multiple isolation points or authority keys to be managed simultaneously, ensuring all necessary conditions are met before access is granted.
- ▶ **Built for Harsh Environments:** Durable die-cast or 316 stainless steel construction with dust-protected barrels ensures long-lasting performance even in demanding industrial settings.
- ▶ **Enhances Control and Accountability:** Requiring multiple key holders to be present before access keys are released strengthens procedural compliance and improves overall site safety.

MULTI-KEY SYSTEM PART NUMBERS

8-WAY (UP TO 2 IN / 6 OUT)



MX-P-8-2X6 PANEL MOUNTED
MX-B-8-2X6 BOX MOUNTED

12-WAY (UP TO 3 IN / 9 OUT)



MX-P-12-3X9 PANEL MOUNTED
MX-B-12-3X9 BOX MOUNTED

20-WAY (UP TO 5 IN / 15 OUT)



MX-P-20-5X15 PANEL MOUNTED
MX-B-20-5X15 BOX MOUNTED

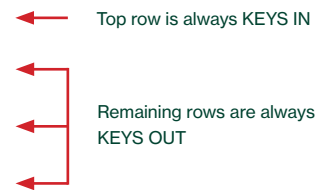

HOW TO ORDER AN MULTI-KEY SYSTEM

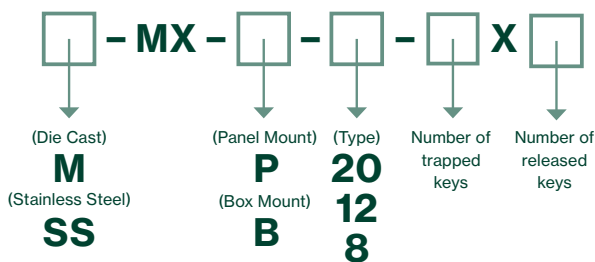

MONITORED KEY EXCHANGE

PANEL MOUNTED CONTROL SWITCH AND KEY EXCHANGE SYSTEM

The **CS-Range** is a versatile trapped key system combining control switch isolation and key exchange functionality. Available in panel- or box-mounted options, it offers flexibility for a wide range of safety applications.

Each key barrel can be configured for monitored (with or without solenoid) or mechanical release. Authority keys are supported for added security, and the -R variant allows reverse operation (key free during normal running).

Typically, the first key controls circuit switching (CS or CS-SKR models), with mechanical keys released only after removal, ensuring a safe operating sequence.

With a fully modular design, the CS-Range scales from simple to complex systems. Components are ordered individually but factory-assembled and configured for quick, ready-to-use installation.

- Any combination of CS, CS-SKR, and KR units can be used, for configurations of up to 10 positions.



CS / CS-SKR

- CS (Control Switch) / CS-SKR (Control Switch with Solenoid)
- Available in die-cast (M) or Stainless Steel (SS)
- 4nc 2no Contacts (240V 3A Max)
- Reverse function available (CS-R / CS-SKR-R)



KR

- Mechanical Key Release Unit
- Available in die-cast (M) or Stainless Steel (SS)
- Reverse function available (KR-R).

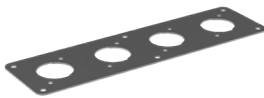

PANEL MOUNT KIT

- Stainless Steel Panel
- Available up to 10-Way

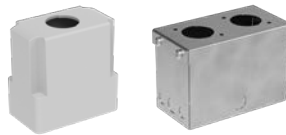

BOX MOUNT KIT

- B-1WAY (Plastic Enclosure)
- B-2WAY Plus (Stainless Steel Enclosure)

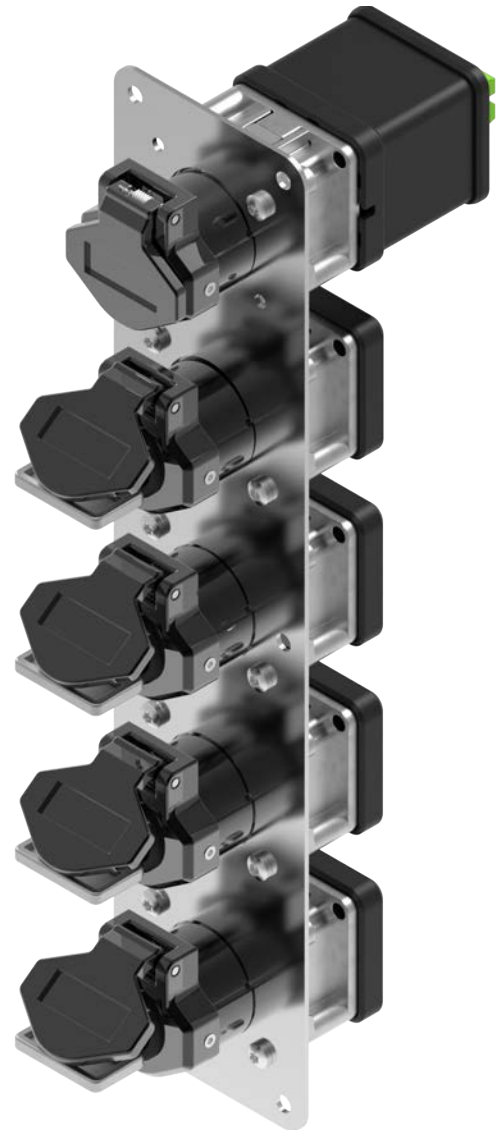

Part Number	Enclosures (Panel Mount)
P-1WAY	Panel Mount Enclosure Kit 1-Way
P-2WAY	Panel Mount Enclosure Kit 2-Way
P-3WAY	Panel Mount Enclosure Kit 3-Way
P-4WAY	Panel Mount Enclosure Kit 4-Way
P-5WAY	Panel Mount Enclosure Kit 5-Way
P-6WAY	Panel Mount Enclosure Kit 6-Way
P-7WAY	Panel Mount Enclosure Kit 7-Way
P-8WAY	Panel Mount Enclosure Kit 8-Way
P-9WAY	Panel Mount Enclosure Kit 9-Way
P-10WAY	Panel Mount Enclosure Kit 10-Way
Enclosures (Box Mount)	
B-1WAY	Box Mount Enclosure Kit 1-Way
B-2WAY	Box Mount Enclosure Kit 2-Way
B-3WAY	Box Mount Enclosure Kit 3-Way
B-4WAY	Box Mount Enclosure Kit 4-Way
B-5WAY	Box Mount Enclosure Kit 5-Way

For larger box mount kits, please contact IDEM Safety Switches

MONITORED KEY EXCHANGE

CONTROL SWITCH AND KEY EXCHANGE SYSTEM IN HEAVY-DUTY ENCLOSURE



The ISB-CBX is a versatile trapped key device that combines control switch isolation and key exchange functionality within a single compact unit. Available in multiple configurations, it provides flexible solutions for a wide range of safety applications.

The bottom key position is electrically monitored (non-solenoid), while the remaining keys are mechanically released once the first key is removed.

Constructed from robust die-cast alloy or rugged 316 stainless steel, the ISB-CBX is engineered for reliable performance in all environmental conditions.

- Die-Cast Version Max. Barrels is 10
- Stainless Steel Version Max. Barrels is 6

HOW TO ORDER AN ISB-CBX

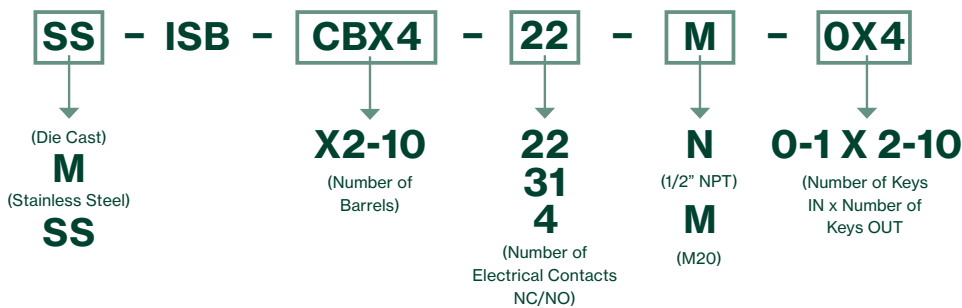

SS-ISB-CBX4-22-M-OX4

SOLENOID CONTROLLED SWITCH AND KEY EXCHANGE SYSTEM IN HEAVY-DUTY ENCLOSURE



The ISB4-X is a versatile trapped key device that integrates control switch isolation and key exchange functionality into a single, compact unit. Available in a range of configurations, it offers flexible solutions to suit a wide variety of safety applications.

The bottom key position is electrically monitored and held captive by an integrated solenoid, ensuring controlled access. Once the primary key is removed, the remaining keys are mechanically released in a predetermined sequence.

Built from robust die-cast alloy or durable 316 stainless steel, the ISB4-X is designed for reliable operation in even the harshest industrial environments.

- Die-Cast Version Max. Barrels is 10
- Stainless Steel Version Max. Barrels is 6

HOW TO ORDER AN ISB4-X

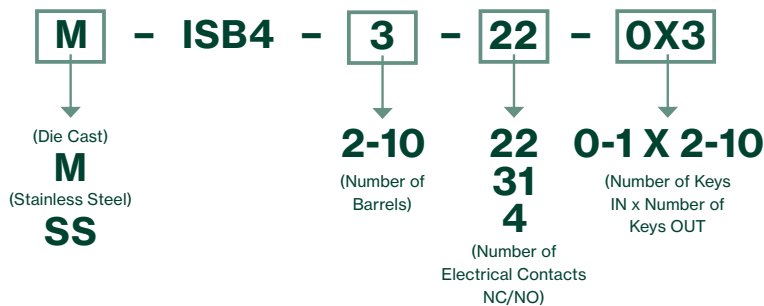

M-ISB4-3-22-OX3

ACCESS CONTROL

WHAT IS ACCESS CONTROL

Access control is the final stage in the trapped key process, allowing personnel to safely enter a hazardous area—either for full-body or part-body access. Access control interlocks ensure that guards or doors remain securely locked during normal operation and can only be opened when a correctly coded key is inserted and turned, thereby enabling safe access to the machine.

SINGLE KEY

When the key is inserted and turned, the interlock releases and the key becomes trapped, preventing its removal. The key can only be released once the guard is closed and the key is turned back to its original position.

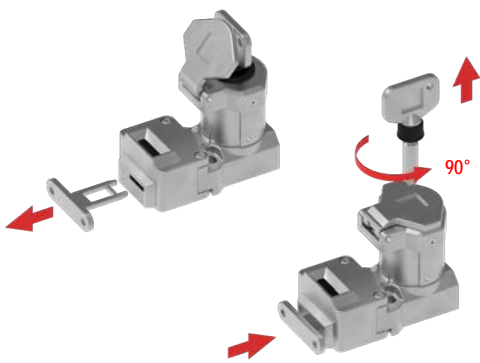

DUAL KEY

When the first key is inserted and turned, the second key is released—allowing the guard to be opened while the first key remains trapped.

The second key, often referred to as the personnel key, should be taken into the hazardous area to prevent accidental restart. The first key cannot be removed until the second key is returned, ensuring a safe and controlled restart sequence.

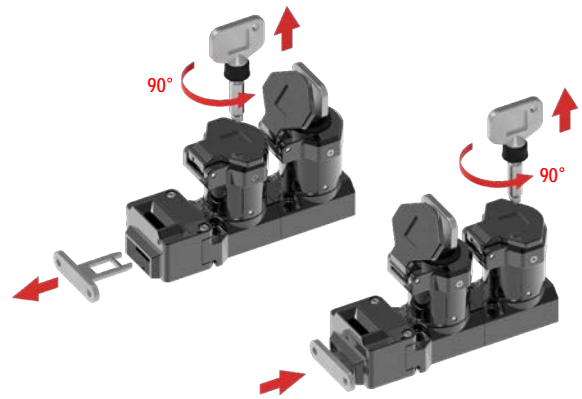

APPLICATION



WOOD PROCESSING

- Suitable for high vibrations
- Rotating head for versatile installation
- No wiring for quick installation and low maintenance

APPLICATION



INDUSTRIAL OVEN

- Suitable for high/low temperatures
- 316 Stainless Steel housing for washdown
- No wiring for quick installation and low maintenance
- Custom labels with zone / gate names

ACCESS CONTROL

TONGUE INTERLOCKS

The Skorpion Tongue Interlock is available in both single-key and dual-key configurations. Designed in compliance with ISO 14119, it incorporates features to minimise the risk of defeat in a reasonably foreseeable manner. Operating modes include Key Trapped / Actuator Unlocked, or One Key Trapped / One Key Free / Actuator Unlocked, offering flexibility to suit various safety applications. Constructed from either robust 316 stainless steel or durable die-cast metal for reliable performance in demanding environments.

- ▶ Durable cam mechanism ensures long-term reliability of our tongue interlocks.
- ▶ 180-degree rotatable head provides enhanced flexibility during installation.

SINGLE KEY



TS

- Key Trapped, Actuator Unlocked
- Available as either Stainless Steel 316 or Die-Cast Metal

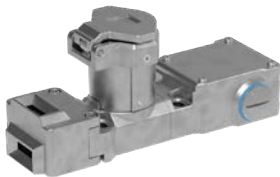

TS-CB (MONITORED)

- Key trapped, actuator unlocked
- 2nc 2no, 3nc 1no or 4nc Contacts
- 240V 3A Max
- Available with 1/2" NPT or M20 conduits
- Available as either Stainless Steel 316 or Die-Cast Metal

DUAL KEY

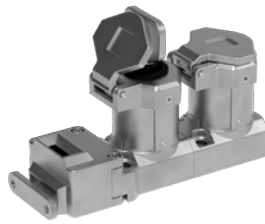

TD-11

- One Key Trapped, One Key Free, Actuator Unlocked
- Available as either Stainless Steel 316 or Die-Cast Metal

APPLICATION



FOOD PROCESSING MIXER

- Suitable for high/low temperatures
- 316 Stainless Steel housing for washdown
- No wiring for quick installation and low maintenance
- Mixer cannot be opened until it is safe

The dual action handle accessory for TS and TD range of trapped key interlocks provides a convenient solution for installation on both sliding and hinge style guards. The handle supports two styles of actuator, standard (A) for hinge operation and (F) for sliding operation. Manufactured from rugged 316 grade stainless steel, they are suitable for use in harsh environmental conditions.



DUAL ACTION HANDLE 140195

COMPATIBLE ACTUATORS (SOLD SEPARATELY)



STANDARD (A) 140107



FLAT (F) 140108



HEAVY DUTY FLEXIBLE (HF) 140101



HEAVY DUTY FLEXIBLE (HFH) 140111

ACCESS CONTROL

HANDLE INTERLOCKS

Skorpion access control interlocks are available with a spring-loaded handle in single or dual key versions. They're ideal for applications requiring a handle or preventing unintentional gate reclosure. Installation is simplified, with no need for custom bracket fabrication.

SINGLE KEY

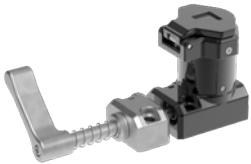

HS

- Key Trapped, Actuator Unlocked
- Available as either Stainless Steel 316 or Die-Cast Metal

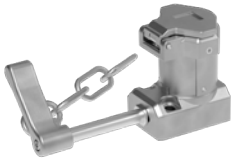

HS-C (WITH CHAIN)

- Key Trapped, Actuator Unlocked
- Available as either Stainless Steel 316 or Die-Cast Metal



HT-S

- Key Trapped, Actuator Unlocked
- Available as either Stainless Steel 316 or Die-Cast Metal

DUAL KEY

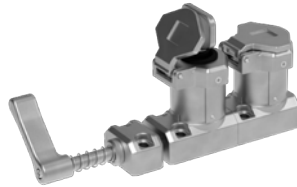

HD

- One Key Trapped, One Key Free, Actuator Unlocked
- Available as either Stainless Steel 316 or Die-Cast Metal

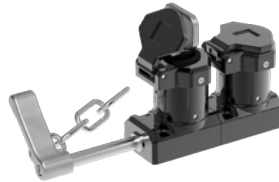

HD-C (WITH CHAIN)

- One Key Trapped, One Key Free, Actuator Unlocked
- Available as either Stainless Steel 316 or Die-Cast Metal

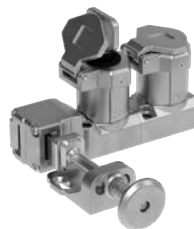

HT-D

- One Key Trapped, One Key Free, Actuator Unlocked
- Available as either Stainless Steel 316 or Die-Cast Metal

APPLICATIONS

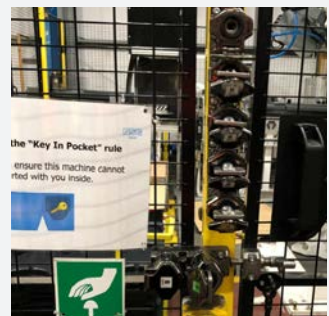
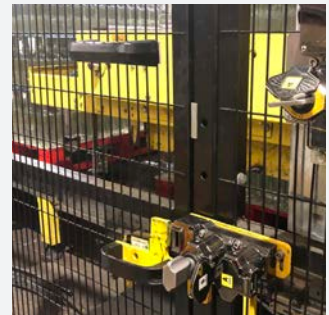
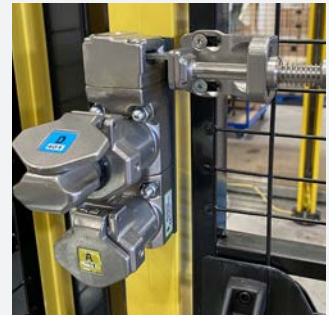

ACCESS CONTROL WITH MONITORING

HANDLE INTERLOCK WITH INTEGRATED CONTACT BLOCK

The HT Handle Interlock with Integrated Contact Block provides a robust mechanical locking solution with built-in electrical feedback capability. Designed for use on hinged or sliding guard doors, this interlock ensures that key exchange and contact switching occur only when the guard is open—providing clear, reliable status indication to control systems.

Available in single key or dual key versions, the HT handle interlock is ideal for safety systems requiring electrical feedback at the access point. The integrated contact block changes state only when the key is turned (gate unlocked), enabling accurate feedback for machine monitoring, interlocking, or safety control circuits.

Key Features:

- Available in Single Key or Dual Key configurations
- Integrated contact block for direct electrical feedback
- Contacts change state only when the first key is inserted or removed
- Suitable for hinged or sliding gates
- Durable, heavy-duty construction for industrial environments
- Ideal for applications requiring verified guard access status

This interlock provides peace of mind in safety-critical environments by combining secure key-based access control with electrical feedback, making it a versatile addition to any safety system.

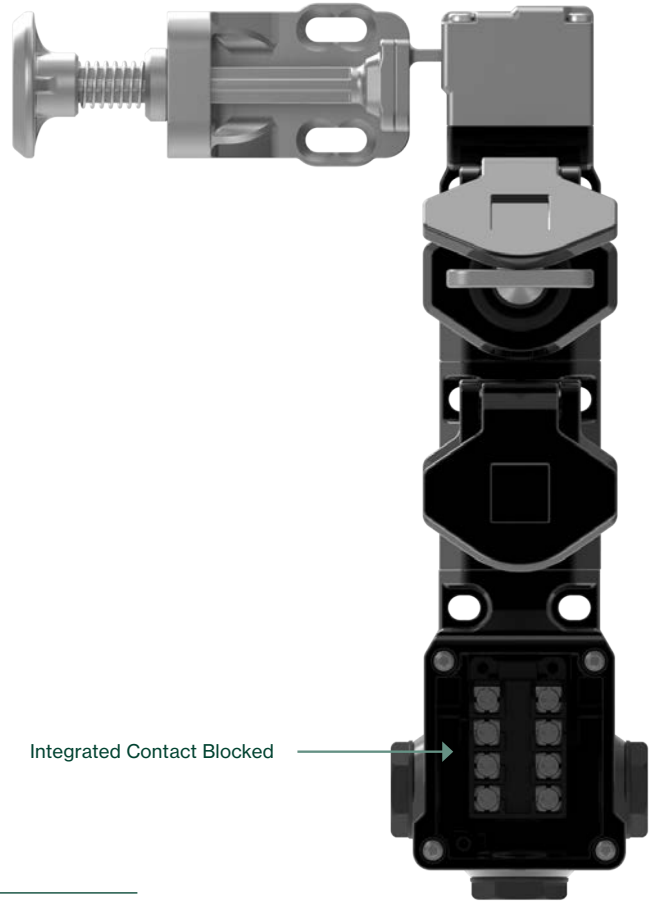

SINGLE KEY

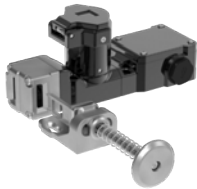

HT-CB (MONITORED)

- Key Trapped, Actuator Unlocked
- 2nc 2no, 3nc 1no or 4nc Contacts
- 240V 3A Max
- Available with 1/2" NPT or M20 conduits
- Available as either Stainless Steel 316 or Die-Cast Metal

DUAL KEY

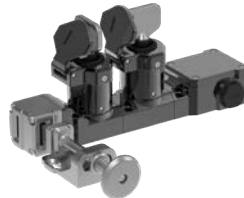

HT-D-CB (MONITORED)

- One Key Trapped, One Key Free, Actuator Unlocked
- 2nc 2no, 3nc 1no or 4nc Contacts
- 240V 3A Max
- Available with 1/2" NPT or M20 conduits
- Available as either Stainless Steel 316 or Die-Cast Metal

ACCESS CONTROL

TS-SR GATE ACCESS SAFETY INTERLOCK WITH SOLENOID CONTROLLED KEY RELEASE

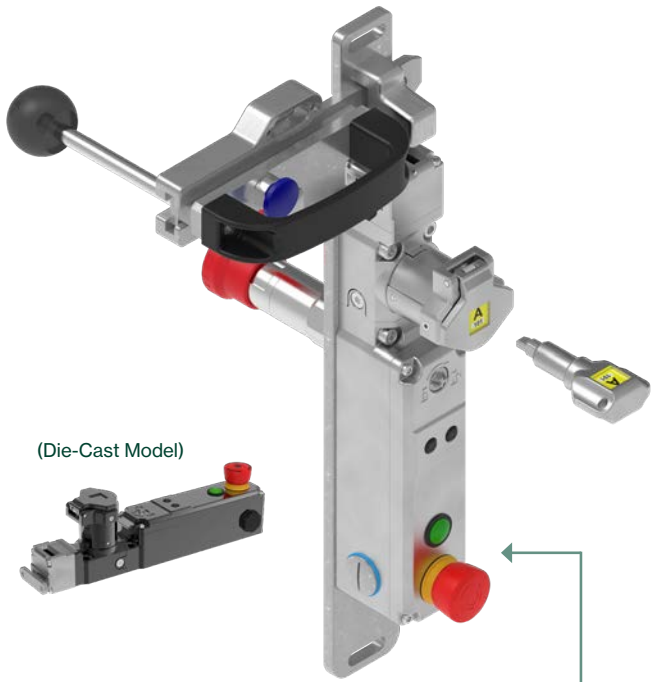

The TS-SR is a solenoid controlled tongue interlock with trapped key, designed to hold machine guards closed whilst the hazard persists.

- Mirror Polished Die-Cast or 316 Stainless Steel
- 1 key released when unlocked
- Rear release functionality
- 3000N Holding force
- LED indication on the lid
- Sliding handle and mounting plate available

HOW TO ORDER A TONGUE INTERLOCK SYSTEM

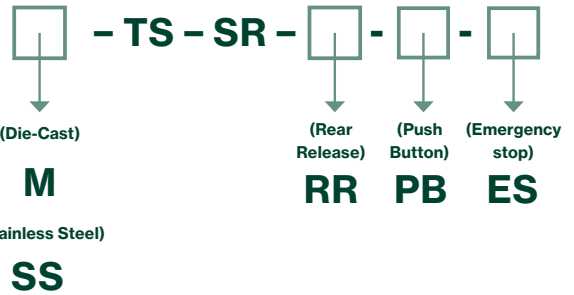

The lid can incorporate 1 x illuminated e-stop and 1 x 16mm pushbutton.

ACCESSORIES

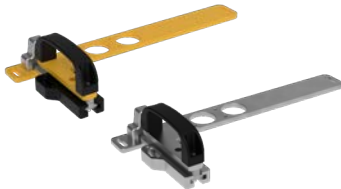

GB-SR GATE BOLT

- Available as either Stainless Steel 316 or Die-Cast Metal
- Includes Sliding Handle and Mounting Plate
- Mounts Directly to the Guarding Frame



SPRING CATCH

- Available as either Stainless Steel 316 or Die-Cast Metal
- Designed to Prevent Accidental Closure of the Gate



REAR HANDLE

- Available as either Stainless Steel 316 or Die-Cast Metal
- Provides a Means of unlocking the Actuator from the Inside

TYPE 4 INTERLOCKS WITH TRAPPED KEY

KLM-Z-SKR RFID CODED INTERLOCK WITH OSSD



KLM-Z-SKR is a solenoid-controlled, RFID-coded tongue interlock designed for safety applications requiring controlled access to hazardous areas. It features OSSD (Output Signal Switching Device) outputs, ensuring compatibility with modern safety PLCs and safety relays.

The device combines mechanical key trapping with electronic solenoid actuation to provide secure access control. When the machine or process is running, the solenoid remains de-energised, and the mechanical key is securely trapped within the interlock. Access to the hazardous area is physically prevented.

To gain access, the solenoid must first be energised via a safety command, typically triggered once the machine is in a safe state. This unlocks the trapped key, allowing it to be turned and removed. Turning and removing the key disengages the tongue actuator, unlocking the guard or door and permitting safe entry to the area.

For enhanced safety, the system ensures that the interlock cannot be reset or restarted until the key has been fully returned and reinserted into the device. This guarantees that all access points are secure before machine operation can resume, preventing accidental restart while personnel are still within the hazardous zone.

The RFID coding provides high-level protection against tampering and ensures that only uniquely paired actuators and interlocks can operate together, further reinforcing system integrity.

KLM-Z-5ST RFID CODED INTERLOCK WITH OSSD AND MACHINE CONTROL

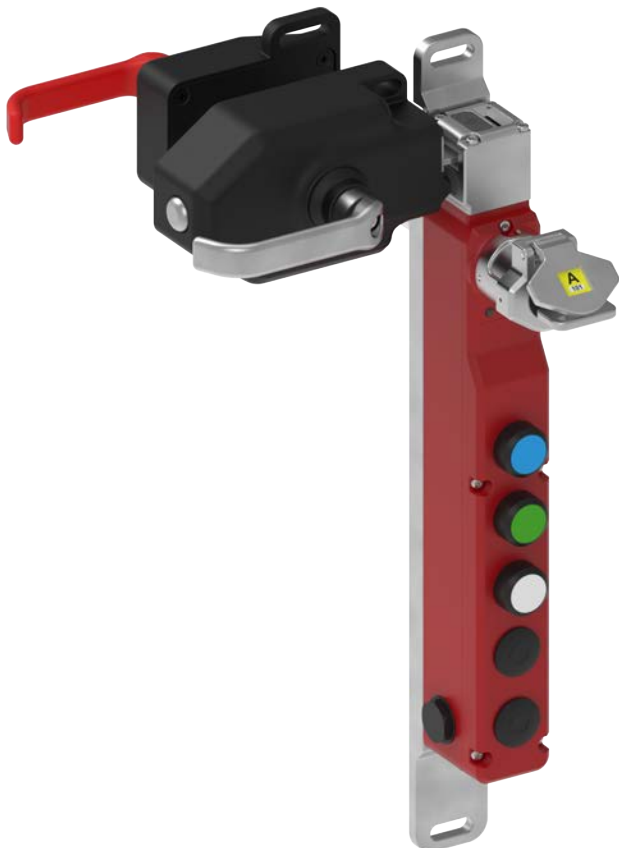

The KLM-Z-5ST is a high-performance safety guard locking switch designed for applications demanding maximum reliability and advanced safety functionality. Featuring RFID-coded actuation and OSSD (Output Signal Switching Device) outputs, the KLM-Z-5ST supports series connection of multiple devices while maintaining safety ratings up to Category 4, SIL3, and PLe.

Engineered for both safety and convenience, the KLM-Z-5ST includes a rugged die-cast metal body and a stainless steel actuator head, ensuring long-term durability even in challenging industrial environments. Its RFID-coded actuator prevents tampering and misalignment, offering a high level of protection against defeat.

A key differentiator of the KLM-Z-5ST is its integrated control interface, with five 22mm mounting positions on the lid for pilot devices such as emergency stop buttons, selector switches, and indicator lamps. This enables localized machine control directly at the guard, improving operator convenience and enhancing safety procedures.

Whether used in standalone systems or daisy-chained in complex safety networks, the KLM-Z-5ST delivers robust, flexible protection for safeguarding personnel and processes.

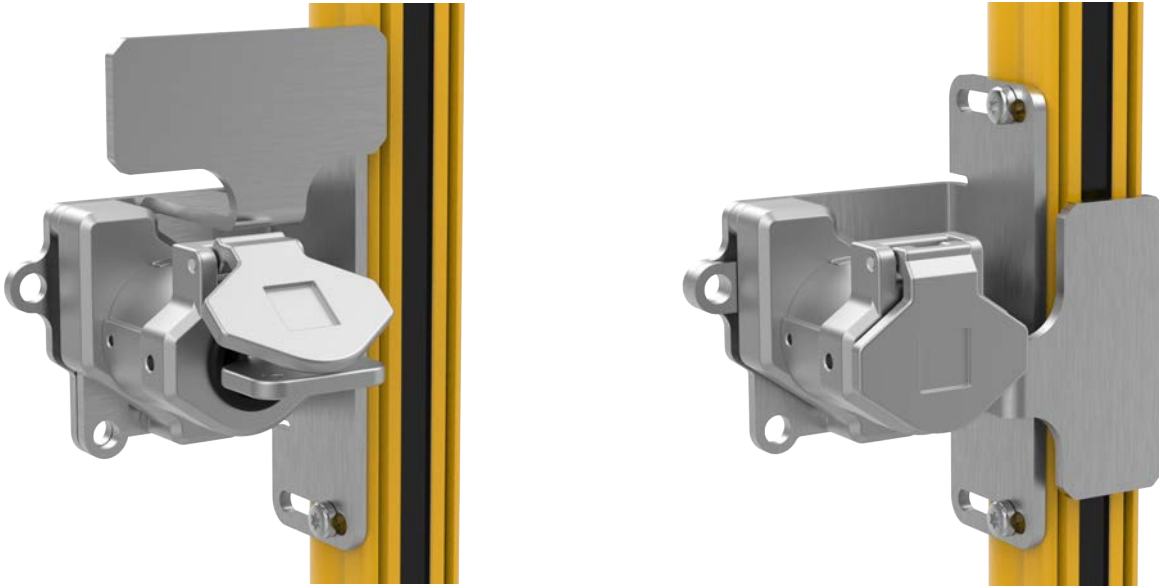

WHAT IS AN LCB LIGHT CURTAIN BLOCKER

The Skorpio Trapped Key Light Curtain Blocking Device, is designed to be installed or retrofitted to provide a prohibitive blocking function, alongside compatible light curtain devices. While the light curtain installation is able to offer maximum accessibility to a machine or production line by removing or complementing the requirement for mechanical guarding, when installed correctly, the LCB device allows the user to safely lock-off and prohibit the re-engagement of the light curtain barrier. It also allows for this lock off to be integrated into a wider Skorpio trapped key system if desired. In addition, the Idem LCB provides dual lock-off functionality, allowing for an 8mm padlock hasp to be applied in either the light curtain operational, or light curtain blocked positions.

HOW IT WORKS

Key inserted and in the open position "light curtain is active".

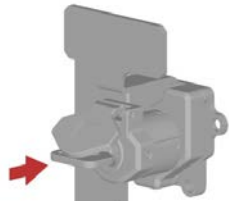

Key is rotated 90 degrees which drives the blocking plate.

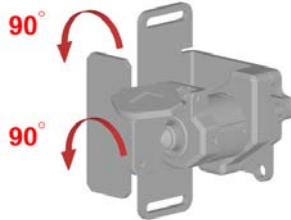

Key is removed and the blocking plate is in the locked position "light curtain is not active".

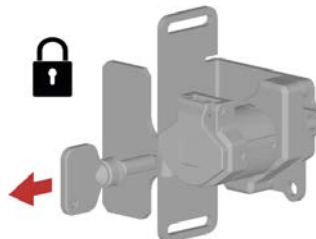

COMPATIBLE WITH LOCKOUT / TAGOUT

Padlock or hasp applied to side lockout, for prevention of LCB Disengagement.



Padlock or hasp applied to bottom position, for prevention of LCB Engagement.



PERSONNEL KEY



Once the key is removed, the operator takes inside the safeguarded area. This "key in pocket" solution reduces the likelihood of an inadvertent startup occurring.

CONTROL SWITCH FOR EXPLOSIVE ENVIRONMENTS

Control switches engineered for use in hazardous atmospheres, where a mixture of air with gases, vapours, mists, or dusts may create an ignitable environment under certain conditions.

All ATEX-certified models are supplied with a standard 3-meter pre-wired cable. Longer cable lengths are available upon request; however, please note that the cable length cannot be altered once the product has been manufactured.



ISB-CB-Ex

- Monitored Control Switch.
- Available with 1NC 1NO, 2NC or 2NC 2NO
- Die-Cast (IP67)
- 316 Stainless Steel (IP69K)



TS-CB-Ex

- Key trapped, actuator unclcked.
- Available with 1NC 1NO, 2NC or 2NC 2NO
- Die-Cast (IP67)
- 316 Stainless Steel (IP69K)
- 3000N Holding Force



THIRD PARTY APPROVAL

The internal contact block has been tested and approved to the above standards.



Exd IIC T6 (-20 ≤ Ta ≤ +60C) Gb



Ex tb IIIC T85C (-20 ≤ Ta ≤ +60C) Db

ZONES 1 / 2 / 21 / 22

EXCHANGE AND ACCESS

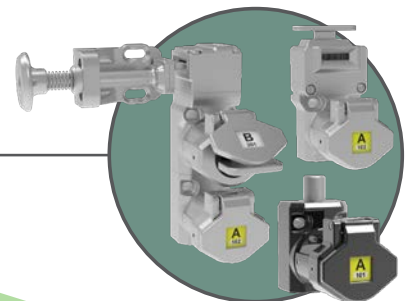

IDEM Trapped Key products are suitable for use in explosive environments. The pure mechanical nature of the access locks means they are suitable for use in Zones up to 0 / 20.

CONTROL ISOLATION

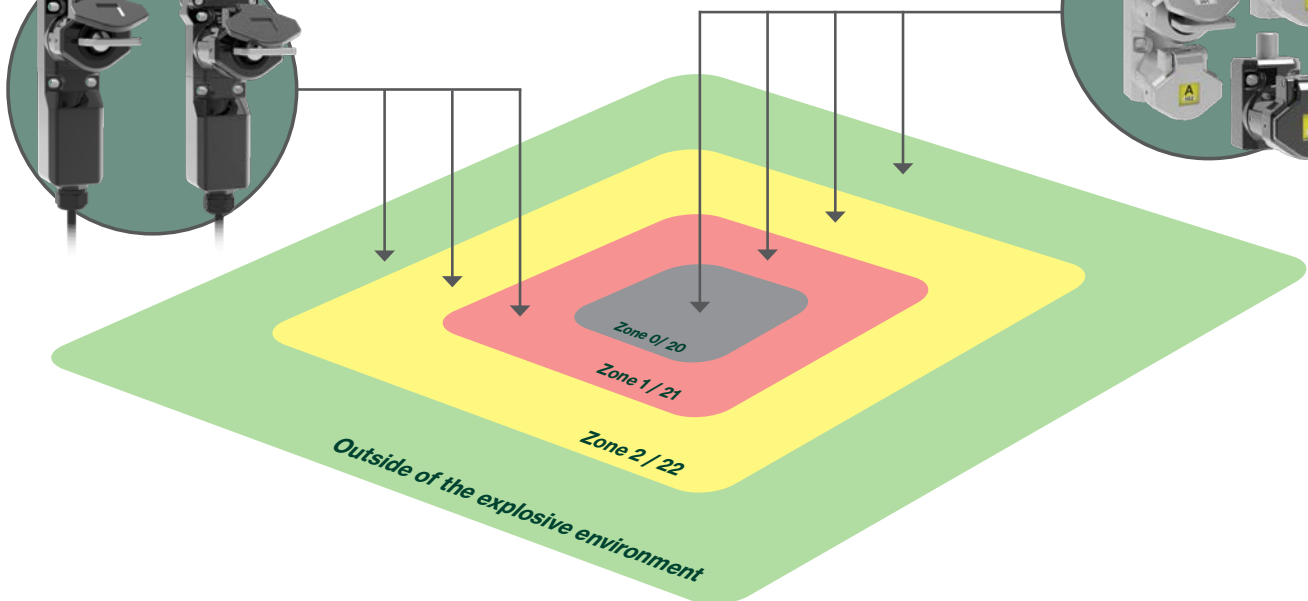
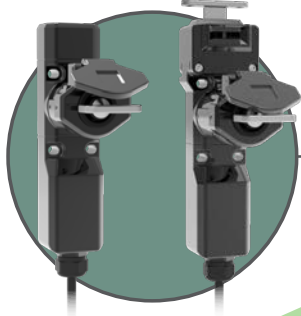

IDEM Safety Switches

Leading Manufacturer of Machine
Safety Switches and Solutions

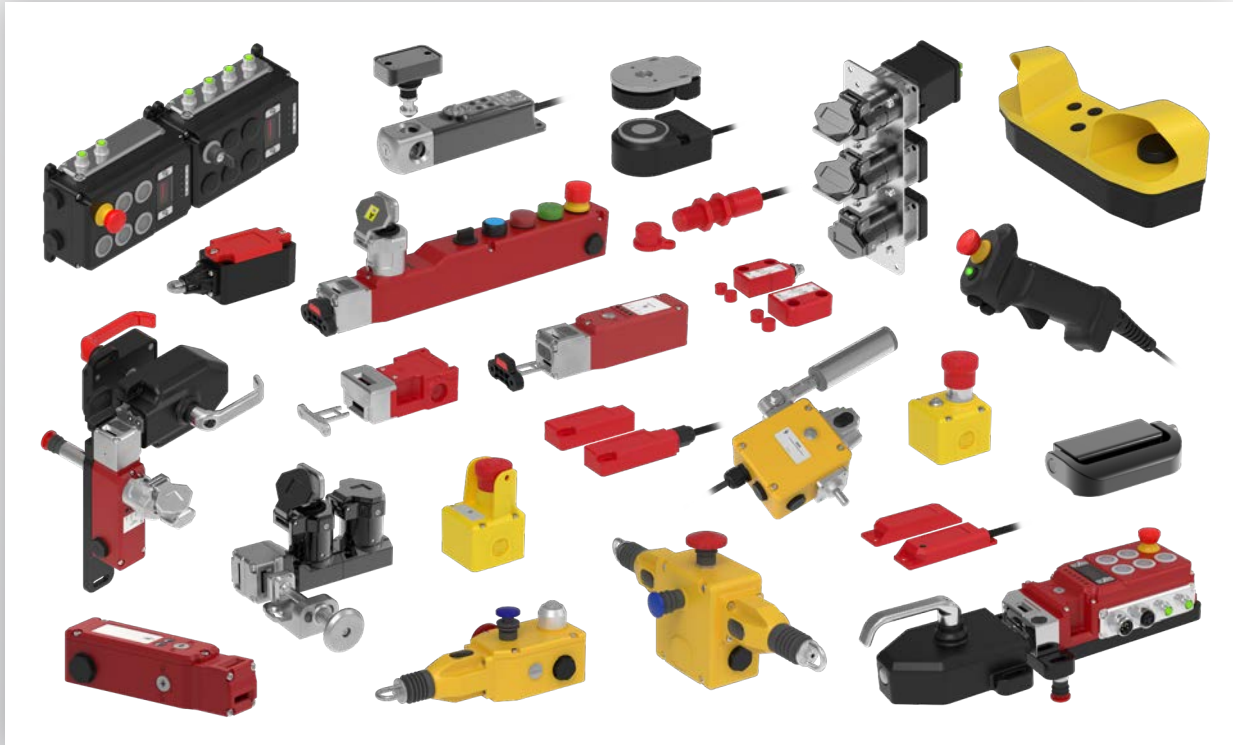

“Your Complete Solution for Machine Safety.”

IDEM Safety Switches LTD

2 Orside Close, Hindley Green
Wigan, United Kingdom
WN2 4HR

+44 (0) 1942 257070
sales@idemsafety.com

idemsafety.com

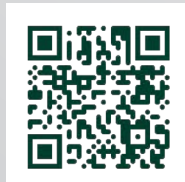

IDEM Safety Switches USA

2574 S. Beverly Street
Boise, Suite 100
ID 83709

+1 (208) 616 5370
salesusa@idemsafety.com

idemsafetyusa.com

